

Qube Series

Standard Features

- Digital temperature controller with alarm
- Built-in condensate evaporator
- Durable 16 gauge welded steel construction
- Efficient, quiet, long lasting rotary compressor
- Environment friendly HFC refrigerant
- Easy pull-out filter
- UL Listed
- Space saving aesthetic cabinet design
- Designed to mount on side of enclosure while maintaining NEMA type 12, 3R, 4, or 4X integrity



Options & Accessories

- Stainless Steel
- Remote Controller Kit
- Replacement Filters
- Corrosive Packages
- Crankcase Heater

Technical Data

Model	BTU	Volts	Max Amps	Weight (lbs.)	Dimensions
IQ3000MM-126	3000	120/60	6.0	45	30.02"Hx6.49"Wx6.02"D
IQ3000MM-236	3000	230/60	3.0	45	30.02"Hx6.49"Wx6.02"D

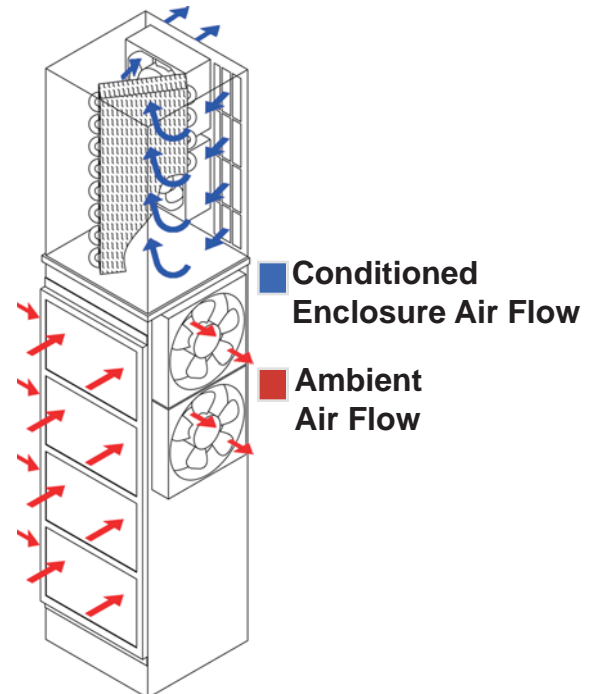
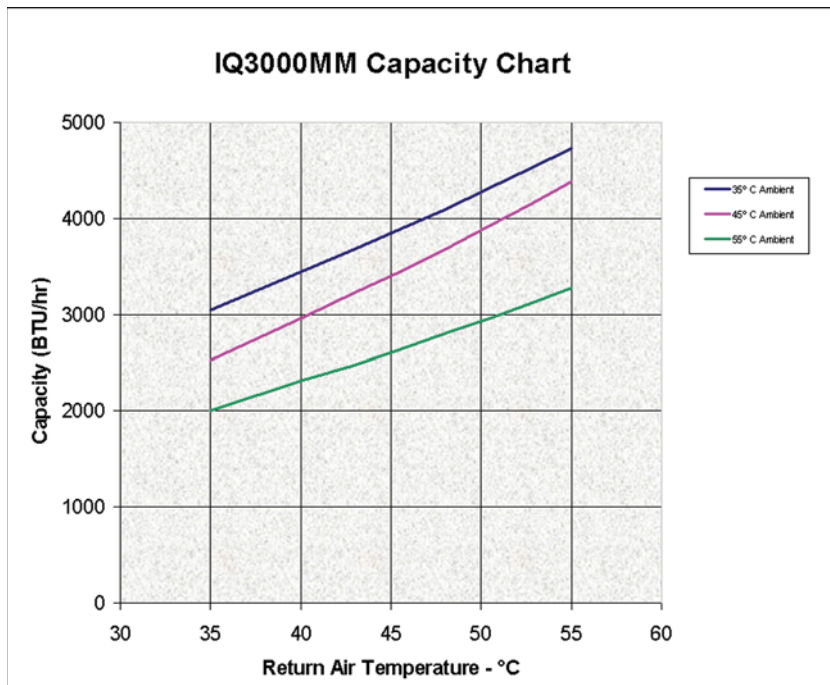

Drawings are for illustration purposes only. Data is subject to change.

TOP VIEW

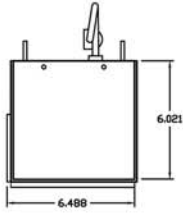

FRONT VIEW

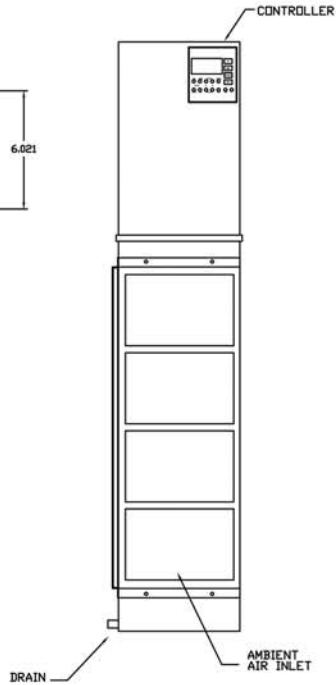

RIGHT VIEW

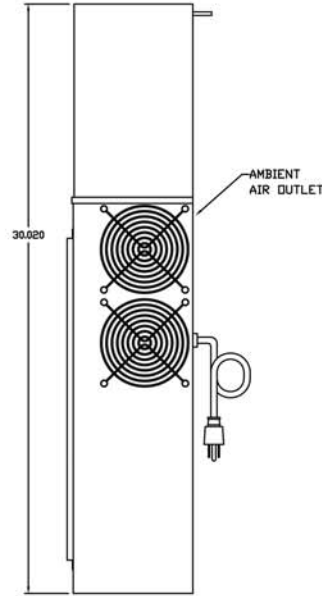

LEFT VIEW

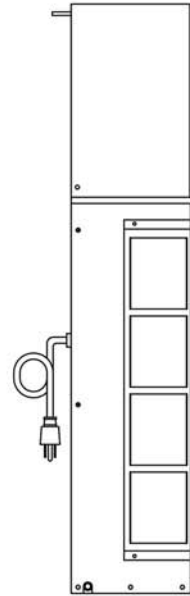

CUTOUT DRAWING

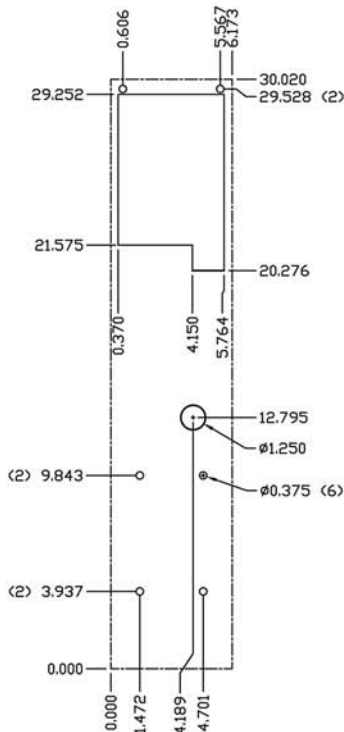

REAR VIEW

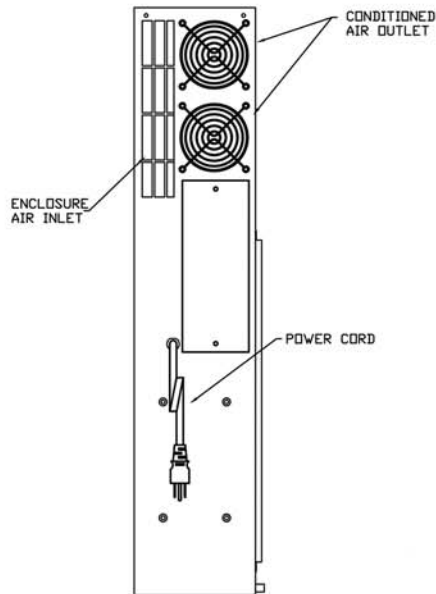

GASKET DRAWING

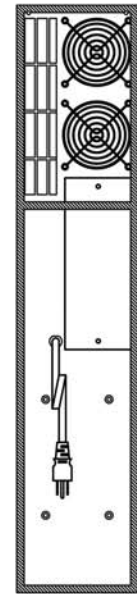

❖IMPORTANT❖
GASKET MUST BE APPLIED AS SHOWN FOR PROPER OPERATION AND TO MAINTAIN NEMA INTEGRITY