



Intelligent Electronic Enclosure Thermal Management Systems



OPERATION AND INSTALLATION MANUAL Mini-Max Air Conditioning Units

***** IMPORTANT *****

PLEASE READ this manual. Follow the instructions for safe and satisfactory installation and operation of this system. Keep this manual for future reference. Some information may not apply to all systems.

TABLE OF CONTENTS

Introduction	Page	3
Basic operation	Page	3
Figure 1: Flow Diagram	Page	3
Unpacking Inspection	Page	4
Pre-Installation Test	Page	4
Preparing the Enclosure	Page	5
Operating the System	Page	7
Programming the Controller	Page	8
Alarm Operation	Page	10
Maintenance	Page	11
Trouble Shooting	Page	12
Trouble Shooting Check List	Page	13
Schematic Wiring Diagram	Page	14
Warranty	Page	15

INTRODUCTION:

Ice Qube's Thermal Management System, TMS, is designed to cool, dehumidify or heat the internal environment of modern electrical enclosures. Ice Qube offers efficient and aesthetically appealing packages that can be mounted on top or on the side of your enclosure. Our closed-loop circulation design protects your equipment from air-borne dust and contaminants which may hinder equipment operations, causing unnecessary down time. Ice Qube is able to provide cooling capacities from 800 to 20,000 BTU per hour - a wide range of cooling systems to satisfy many of your conditioning needs.

BASIC OPERATION:

The Ice Qube's Thermal Management System, TMS, is actually a combination of three independent systems which function simultaneously to maintain environmentally friendly conditions for various types of electronic equipment enclosures. These three thermal related systems are: the closed-loop cool air system; the warm air system; and the vapor-compression refrigeration system. Please refer to Figure 1.

The closed-loop cool air system circulates cold air from the Ice Qube TMS to the electronics enclosure. This air returns to the Ice Qube system bringing with it unwanted heat and humidity from inside the enclosure. Heat and humidity is then removed by a heat exchanger located within the Ice Qube TMS. This heat exchanger is part of the vapor-compression refrigeration system.

At the heart of the vapor-compression refrigeration's system is a quiet, energy efficient rotary compressor which circulates environmentally friendly NON-CFC refrigerant. The main purpose of this compressor is to transfer heat laden refrigerant from the evaporator, located within the closed-loop cool air system, to a condenser, located in the warm air system. In the warm air system, air is circulated from the ambient surrounding the enclosure, through a filter, and across the warm air system heat exchanger. Here, heat from the enclosure is transferred from the warm air heat exchanger into the warm air stream and dissipated to the ambient.

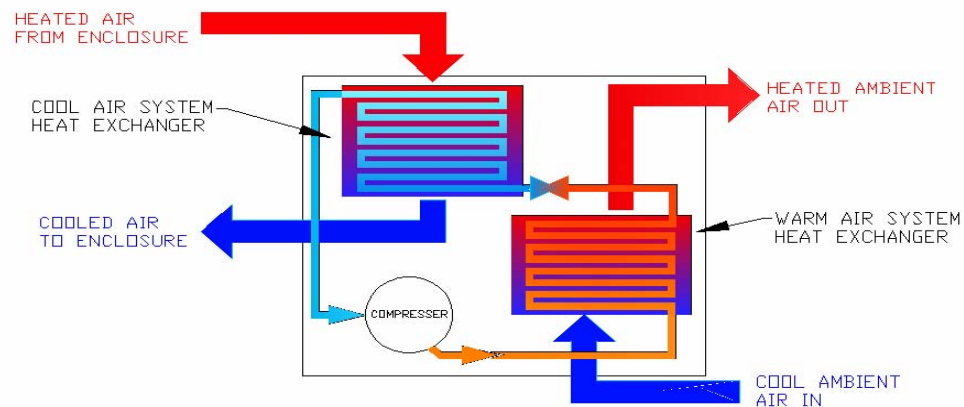

Figure 1: Flow Diagram

UNPACKING INSPECTION:

1. The shipping container leaves the factory banded to a pallet with red arrows imprinted on the box. These red arrows should be pointing in the proper (upward) direction. The Ice Qube TMS is position sensitive. Ice Qube recommends the unit to remain in the proper upright position for a minimum of 24 hours before initial operation. This is to ensure the oil has returned to the compressor. Operation before the 24 hour time period may cause damage to the compressor, hence shortening the life of the system.

Note: Operating the unit before maintaining an upright position for 24 hours will void all warranties.

2. Check for any damage to the shipping container. If the shipping container has been damaged or marred in any way, carefully check to see if the Ice Qube TMS incurred any damage. Check for scratches, dents, rattles (which may indicate loose components), the presence of oil, and any other irregularities. Any evidence of damage will need to be recorded on the freight bill and reported to the carrier. The freight carrier will provide instructions on filing a claim. **Ice Qube cannot accept responsibility for damages that occur during shipping.**

PRE-INSTALLATION TEST:

Before installing the Ice Qube system on the enclosure, it is recommended the unit operate for 20 to 30 minutes to ensure it is functioning properly. Although the Ice Qube TMS has been tested at the factory, internal damage may have occurred during shipping which may have not been apparent during the unpacking inspection.

1. Place the system on a solid base such as a workbench or table. Be sure to allow adequate space for airflow. There are two air streams that must not be restricted, the cool air stream and the warm air stream. Units can only be mounted on a flat vertical surface.
2. Check that the warm air system filter is in place, location varies with model type.

Models with the optional rain or wash down hood do not have a warm air filter and may require regular routine condenser maintenance.

3. Check the data tag for proper electrical requirements. The data tag lists the design voltage and amperage requirements of the system. Verify that the electrical outlet where the system will be connected has the proper capacity. After noting the above, connect the power cord to a properly grounded electrical connection. The use of an extension cord is not recommended.

NOTE: If any unusual noise or vibration is present during the testing procedure, immediately disconnect the power cord and inspect the unit for the cause of the noise or vibration. Contact Ice Qube immediately.

4. As soon as power is supplied to the system, the cool air evaporator blower will begin to operate. The compressor and warm air condenser blower will not operate if the room air temperature is below 80°F. This is due to the fact the programmable controller has a factory setpoint of 80°F. (The digital display on the face of the controller will be displaying room temperature.) If the display is indicating 80°F or warmer, the “Cool” status LED will flash for 3½ minutes before the compressor and the warm air condenser blower will operate.

If the display is indicating a temperature less than 80°F, adjust the setpoint to a temperature lower than the room temperature in order for the compressor and warm air condenser blower to operate. Refer to the “Programming the Controller” section of this manual in order to change the factory set points.

5. With the compressor and both blowers functioning, allow the unit to operate for 20 to 30 minutes. This will provide sufficient time for the vapor compression system to achieve equilibrium. Measure the cool air outlet temperature with an accurate thermometer. This temperature should be at least 10 degrees colder than the inlet air temperature, (if the room temperature is warmer than 70°F). Inlet air temperature will be displayed on the programmable controller. In areas of high humidity, the temperature difference may be less than 10 degrees.
6. After completing the above check points, the electrical enclosure is ready to be prepared for the installation of the Ice Qube system.

PREPARING THE ENCLOSURE:

Ice Qube air conditioning systems have been designed to be light weight for ease of installation. Side enclosure or vertical mount units have been designed with a simple “two stud” alignment feature to make initial fastening to the enclosure quick and easy. A few modifications must be made to the enclosure to provide proper airflow, to maintain enclosure integrity and to assure a secure installation. Required modifications will vary with each air conditioner model.

1. Determine the location of the Ice Qube system on the enclosure.

*** CAUTION ***

Verify the weight of the air conditioning system will not cause the enclosure to become unbalanced. Equipment instability may cause bodily harm or equipment damage. For units mounted on enclosure doors, confirm the hinges will support the weight of the Ice Qube system. Refer to system specifications for model weights.

2. Upon deciding the location of the Ice Qube system on the enclosure, attach the included template to the enclosure surface. This template drawing will assist the installer in placing the air conditioning unit on the enclosure. Be sure that the Ice Qube system will be mounted level and the cool air inlet and outlet connections will not be restricted by equipment or shelving within the enclosure. Also check that the air flow of the warm air stream will not be effected or restricted by the surroundings.

3. Outline the modifications to be made to the enclosure with a marking pencil. Note the bolt hole locations, the cutouts for the inlet and outlet air streams, the power cord, and locations for any optional equipment. Additional cable openings may be required for units with optional heating or alarm outputs, or for units connected to a network communications link.
4. Using a drill, make the holes for the studs, bolts and power cord, and any other option. The bit size will need to vary depending upon the model. Protect any equipment located within the enclosure from debris produced during the installation procedure.
5. Drill a pilot hole for a saber saw to cut the inlet and outlet air passages. File all cuts to provide a uniform cutout.
6. Slide the mounting studs through the matching holes in the enclosure and check to see if all of the openings are aligned. Top mount units do not have mounting studs.
7. After checking that all openings and bolt holes are in alignment, apply the gasket material provided to the Ice Qube air conditioning system cabinet to ensure enclosure integrity.

***** CAUTION *****

Be careful while removing the backing on the gasket material. The material may stretch and the holes will not align.

NOTE: If the enclosure is not air tight, or the air conditioning system operates with the enclosure door(s) open, moisture will condensate inside the air conditioning system and may cause the condensate management system to overflow.

8. After the gasket material has been installed, mount the Ice Qube system onto the enclosure and fasten it using the supplied nuts and bolts. Check to see if the power cord and all optional cables are in place. Fasteners need to be tightened securely and the gasket material needs to be in place in order to maintain enclosure integrity. The gasket material should be slightly compressed with no visible gaps. The Ice Qube system is now ready to begin operation.

NOTE: Near the bottom or on the side of the Ice Qube system cabinet is a nipple for condensate overflow. Although all vertical or side mounted Ice Qube air conditioners have built-in condensate management systems, it may be necessary to attach a drain hose to this nipple on enclosures which are located in extremely humid conditions, or where enclosure doors are left open or the door seals are leaking.

OPERATING THE SYSTEM:

Once the Ice Qube system has been installed onto the enclosure and the power cord has been attached to a properly grounded electrical outlet with adequate voltage and current supply, the unit is ready for operation. As soon as electrical power is supplied to the Ice Qube system, the cool air stream blower will start to operate. The blower will run continuously so that the controller can monitor the enclosure's internal temperature. The enclosure temperature will be displayed on the face of the controller.

If the enclosure temperature is greater than the factory cooling setpoint of 80°F, the "Cool" status LED will flash. This indicates that the compressor's automatic off cycle timer is working. (The off cycle timer is factory set at 3½ minutes). At the end of 3½ minutes, the compressor and the condenser air blower will begin to operate. This signifies that the cooling system has begun operation to remove heat and humidity from the enclosure. This procedure may take 20 to 30 minutes before it reaches full capacity.

If the heat load within the enclosure is less than the cooling capacity of the Ice Qube system, the temperature on the digital display will begin to decrease. When the temperature inside the enclosure decreases 7 degrees Fahrenheit below the 'cooling on' setpoint, the compressor and the condenser blower will cycle off. The cool air blower will continue to operate, circulating air within the enclosure. The controller has a factory programmed temperature differential of 7 degrees Fahrenheit. Example: "Cooling on" @ 80°F; "Cooling off" @ 73°F.

Ice Qube also offers an optional External Heat Output (EHO) to provide power to an external heater, typically located within the equipment enclosure. If the enclosure temperature is below the factory heating setpoint of 50° F, the heat status LED will be on. This indicates that the heat relay has been energized and is providing power to the field connected heater. (There is no time delay before heating begins). When the temperature of the enclosure rises 7 degrees Fahrenheit above the setpoint, the controller will de-energize the heat relay and cycle the heater off.

NOTE: There is a dead band programmed into the controller that prevents heating and cooling from operating simultaneously.

See label attached to the rear of the air conditioner for maximum wattage heater that may be connected to the External Heat Output (EHO).

PROGRAMMING THE CONTROLLER:

The digital controller has many features that may or may not be required for your application. However, the controller has been programmed at the factory with typical default settings for immediate system operation. Please review the following default settings:

1. Cooling system on temperature	80° F
2. Heating system on temperature	50° F (optional)
3. High enclosure temperature alarm	100° F
4. Low enclosure temperature alarm	40° F
5. Audible and Visual alarm	“ON”
6. Digital display in degrees	Fahrenheit
7. Filter maintenance alarm	0 days - Disabled
8. High condenser temperature alarm	170° F

To change the factory default settings, enter the programming code sequence:

“+” (plus sign)
“-” (minus sign)
“Select”
“Exit”

After pressing the above sequence the program LED should illuminate along with three alternating flashing boxes on the display face, indicating the code was accepted. If no selection is made within one minute, the system returns to the normal operating mode.

Note: Pressing the “Exit” button at any time while in the programming mode returns the controller to the normal operating mode.

Press the “Select” button to continue programming. The set temperature “HI” LED illuminates with the display indicating the ‘cooling on’ setpoint. The compressor will begin operation at this temperature and will remain operating until the enclosure temperature decreases approximately seven degrees Fahrenheit (four degrees Celsius).

Press the “+” or “-” buttons until the desired set point is displayed. The range for this adjustment is 70° to 126°F, (21° to 52°C). When the adjustment is complete, press the “Select” button to continue.

The set temperature “LO” LED is *on* with the display indicating the (optional) ‘heating on’ set point. The heating system will begin operation at this temperature and remain operating until the enclosure temperature increases approximately seven degrees Fahrenheit (four degrees Celsius). Press the “+” or “-” buttons until the desired set point is displayed within a range of 0°F to 63°F (-17.8°C to +17°C).

NOTE: Review alarm settings if the ‘cool on’ or ‘heat on’ set points have been changed,

Press the **“Select”** button to continue. The set alarm “HI” LED is *on* with the display indicating the high temperature alarm setpoint. The alarm will activate at this temperature and will automatically reset at two degrees Fahrenheit (one degree Celsius) below this temperature. Press the **“+”** or **“-”** key pads to change the alarm setpoint within a range of 8°F (or 4°C) above the set temperature “HI” set point, to 135°F (or 57°C).

Press the **“Select”** button to continue. The set alarm “LO” LED is *on* with the display indicating the low temperature alarm set point. The alarm will activate at this temperature and will automatically reset at two degrees Fahrenheit (or one degree Celsius) above this temperature. Press the **“+”** or **“-”** key pads to change the alarm setpoint within a range of 8°F (4°C) below the set temperature “LO” set point, to 34°F (or 1° C).

Press the **“Select”** button to continue. The alarm LED will flash and the display will show **“ALL”**, indicating the **“ALL”** alarm on/off status. Press **“Select”** and the display will show either **“ON”** or **“OFF”**, indicating current alarm status. Press the **“+”** or **“-”** key pads to toggle the mode as desired. If the **“OFF”** mode is selected, no alarms will activate and the audible on/off select function is skipped.

Press the **“Select”** button to continue. The audible LED will flash and the display will show **“AUD”**, indicating the audible alarm on/off status. Press **“Select”** and the display shows **“ON”** or **“OFF”** indicating the current audible alarm status. Press the **“+”** button or the **“-”** button to toggle the mode as desired.

Press the **“Select”** button to continue. The **“C”** LED flashes and the display shows either **“F”** for degrees Fahrenheit or **“C”** for degrees Celsius. Press the **“+”** button or the **“-”** button to toggle the mode as desired.

Press the **“Select”** button to continue. The code LED is on and the display shows **“PIN”**. To set a new user PIN code, press the **“+”** button. The display will flash **“4”**, prompting an entry of a four button sequence using the **“+”**, **“-”**, **“Select”** and/or **“Exit”** buttons. (Any sequence of the four buttons may be programmed as the code.) As the buttons are pressed, the display will show the number of buttons that were pressed.

NOTE: After pressing a button, there will only be 5 seconds to press the next button. If the next button is not pressed within the allotted time, the system will default to no PIN code, indicated by “0” on the display. Once the sequence is entered the display will no longer flash, and will show “4”.

To program the no PIN code mode, press **“-”** and the display will show **“0”**, indicating no PIN code. With no PIN code, pressing any button will permit access to the program.

***** CAUTION *****

Always record the selection sequence (PIN code) and store in a secure place.

Press the **“Select”** button to continue. The filter LED flashes and the display will show *“FIL”*, indicating the filter alarm days selection. Press the **“Select”** button and the display will show the number of days that the alarm is set in one-half day increments. (Example: 10.5 indicates the alarm will activate every ten and one-half days).

Press the **“+”** or the **“-”** key pads to vary the desired number of days. (Range is 0-99 days). Programming 0 days will disable the alarm.

NOTE: The required number of days to set this alarm will be determined by the ambient air conditions. If rain or wash down hoods are installed on the system, no filter is supplied and the filter alarm should be set to “0”. This will disable the filter alarm.

Press the **“Select”** button to continue. The program LED will be lit and the display will show *“Add”*. Press the **“Select”** button again and a value of *“0.0”* will appear. Programming of the microprocessor is now complete.

Press the **“Select”** button to review all of the settings. Press the **“Exit”** button to enter the selected settings and to return to the normal operating mode.

NOTE: If the “Exit” button is not pressed, any changes to the program settings will not be saved.

ALARM OPERATION:

1. **The enclosure temperature is above or below the alarm setpoint:**
The alarm LED will light, the display flashes, either *“HI”* or *“LO”* LEDs flash with the display and the audible alarm sounds (if activated). The enclosure temperature must rise or fall two degrees Fahrenheit (one degree Celsius) before the alarm will reset.
2. **The condenser temperature is above the condenser alarm setpoint:**
The alarm LED lights, the display flashes the condenser temperature, and the audible alarm sounds (if activated). The condenser temperature must fall four degrees Fahrenheit (two degrees Celsius) before the alarm will reset. **The above alarms can be manually reset by entering the PIN code into the system.**

3. **The filter day timer has expired:**

The alarm LED lights, the display flashes showing “*FIL*”, the filter LED flashes with the display and the audible alarm sounds (if activated). The filter alarm may be cleared by pressing “**Exit**”.

4. **Sensor Malfunctions:**

- E-O - Evaporator sensor open
- E-C - Evaporator sensor shorted
- C-O - Condenser sensor open
- C-C - Condenser sensor shorted

NOTE: An alternating E-O ... C-O display may indicate the sensor connector has become disconnected from the rear of the controller.

MAINTENANCE:

The Ice Qube air conditioning system is designed to provide many years of trouble-free operation with minimal amount of maintenance. Primary maintenance consists of checking the condition of the ambient air filter and the condensate management system.

1. **Ambient Air Filter:** It is recommended that the ambient air filter be inspected and cleaned regularly, at least every 30 days, or more frequently depending upon ambient conditions. To check the condition of the air filter, it is recommended to first remove electrical power from the Ice Qube system. Next, locate the filter cover and filter, (location will vary by model). Slide the filter from the filter rack through the end slot, and clean by soaking in warm soapy water. Rinse with clean water. Use a shop-vac to remove excess water from the filter before returning it to the system. Replace the filter if it is showing signs of deterioration.

NOTE: If rain or wash down hoods have been installed, a filter would not have been supplied, therefore no filter maintenance is required. However systems equipped with rain or wash down hoods will require regular condensing section maintenance by qualified personnel. For systems equipped with filters, it is recommended to have a spare clean filter in stock in order to prevent prolonged cooling system downtime. The dirty filter may be cleaned at a more convenient time.

2. **Condensate Management System:** The condensate management system should be checked periodically for scale, sludge and debris that may cause the system to fail. On open type enclosures and in areas where the enclosure door is opened frequently within dirty or industrial environments, maintenance should be performed on a regular basis. On sealed enclosures, clean environments, or where the door is not opened frequently, maintenance may be performed annually. *The type of environment will determine the frequency of required maintenance.*

Maintenance of the condensate management system will require removal of electrical power from the Ice Qube system and removal of the cover. To remove the cover, use a screw driver to loosen the screws which attach the cover to the base.

***** CAUTION *****

Electrical wires are connected from the cover to the base.

Removing the cover will allow access to the primary condensate management pan, which is located below the evaporator. Inspect the condensate pan and the drain nipple for signs of scale, sludge or debris that may prevent water flow through the nipple. To clean the debris from the pan, use a clean absorbent cloth or shop-vac. Nipples may be cleaned using a ¼ inch tubing brush, then flush with clean water.

Also inspect the neoprene tubing that is attached to the nipples on the condensate management system. Replace the tubing if it appears to have internal build-up or has become brittle.

NOTE: If there is a secondary condensate management pan, maintenance will need to be performed in the same manner as explained above.

After all debris has been removed from the system, replace the cover onto the unit – being careful not to pinch or damage the wiring connecting the cover to the base.

3. **Cooling system cabinet:** The cooling system cabinet may also need to be cleaned occasionally. To clean the system cabinet, simply wipe it with a damp, lint free cloth. A mild soap solution may be used if necessary.

TROUBLE SHOOTING:

Contact Ice Qube if the air conditioning system should fail to operate satisfactorily during the first year of operation. **DO NOT** remove the cover without first notifying the factory. **Removal of the cover will immediately void the warranty.**

If an operating problem should occur, please review the items outlined in the following “Trouble Shooting Check List”. If the problem persists, contact Ice Qube for technical assistance.



TROUBLE SHOOTING CHECK LIST

Model No:		S/N Number:		
Voltage Rating:	Amps:	Phase:	Hz:	
Is electrical power available at the outlet?			YES	NO
Is the power cord connected to the proper electrical outlet?			YES	NO
Is the controller set point temperature above the enclosure temperature?			YES	NO
Is the evaporator (cold air stream) blower operating?			YES	NO
Is the compressor and condenser (warm air stream) blower operating?			YES	NO
Is the enclosure door closed tightly?			YES	NO
Are all of the gaskets in place?			YES	NO
Has the warm air filter been cleaned or changed recently?			YES	NO
Is the system mounted level on the enclosure?			YES	NO
Is there adequate space within the enclosure for air flow?			YES	NO
Is there adequate space around the enclosure for air flow?			YES	NO
Have you recently added electronic equipment to the enclosure?			YES	NO

Still experiencing Problems?
Call Ice Qube at 1-888-867-8234

SCHEMATIC WIRING DIAGRAM

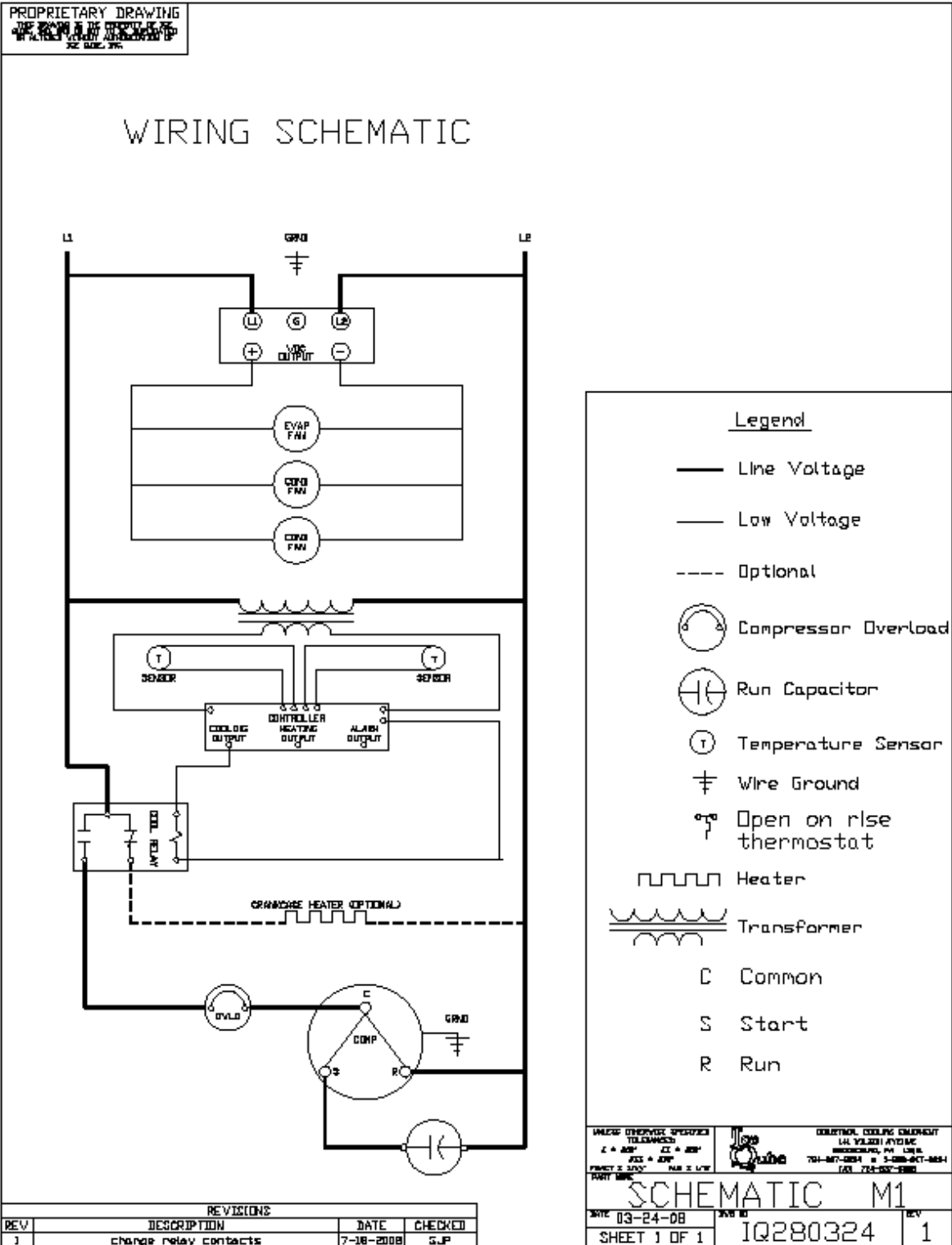

WARRANTY:

The Seller warrants to the original Buyer that the products manufactured by the Seller are free from defects in material and workmanship. If the Buyer notifies the Seller within ONE YEAR of any such defects (the “Warranty Period”), and returns the products to Seller at Buyer’s sole expense, Seller shall, at its option, repair the products, or replace them with products of comparable value. In either case, the Warranty Period for the repaired or replaced products shall extend after the date of repair or replacement for a time equal to the original warranty period. If the Buyer does not notify the Seller of such defects, whether patent or latent, within the Warranty Period, Seller shall have no further liability or obligation to the Buyer. Therefore, in no event shall Seller’s liability under this warranty exceed the original purchase price of the products which are the subject of a proper notice of defects.

Excluded from this transaction are all implied warranties, including without limitation, the implied warranties of merchantability and fitness for a particular purpose or use. The express warranties set forth above are the only warranties given by Seller in this transaction.

In no event will Seller be liable for any incidental or consequential damages of the Buyer. The foregoing remedies are the sole and exclusive remedy of Buyer for any breach of warranty in this transaction.