

BDC SERIES

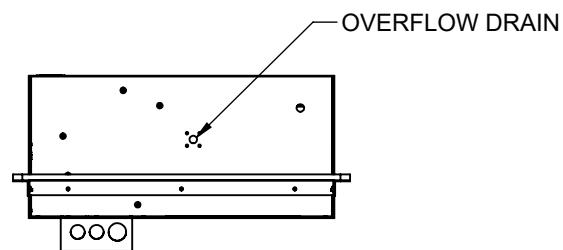
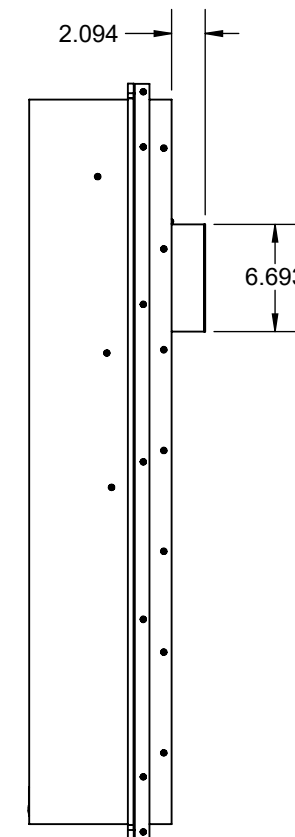
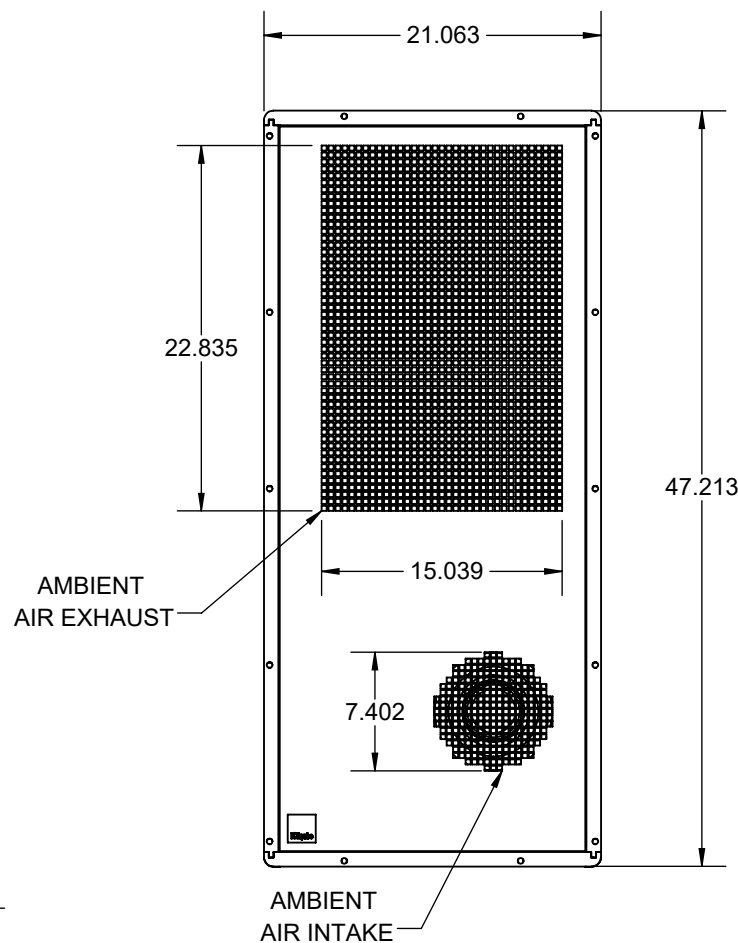
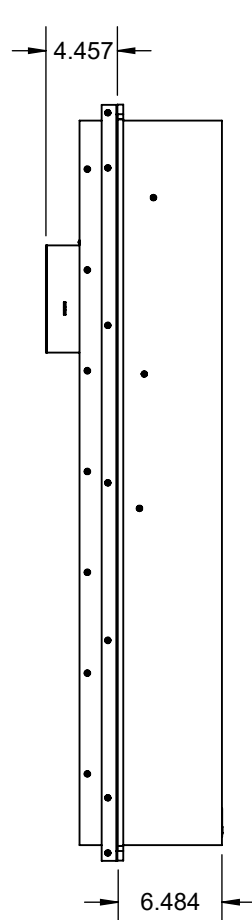
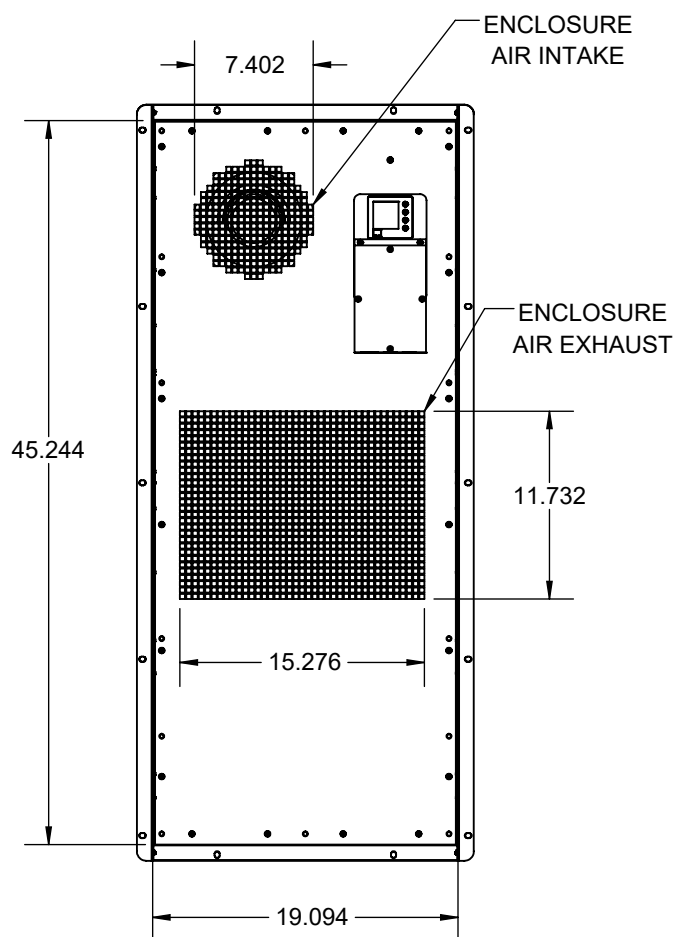
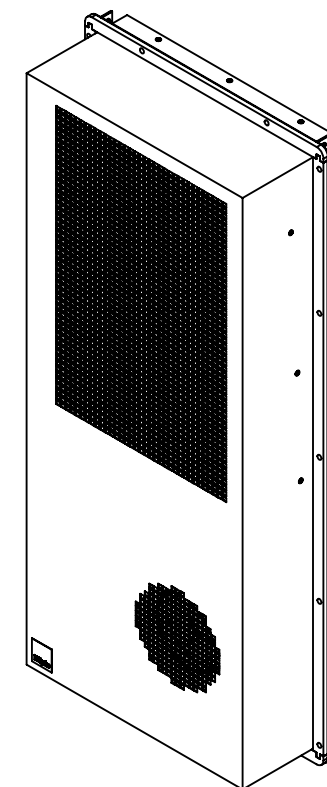
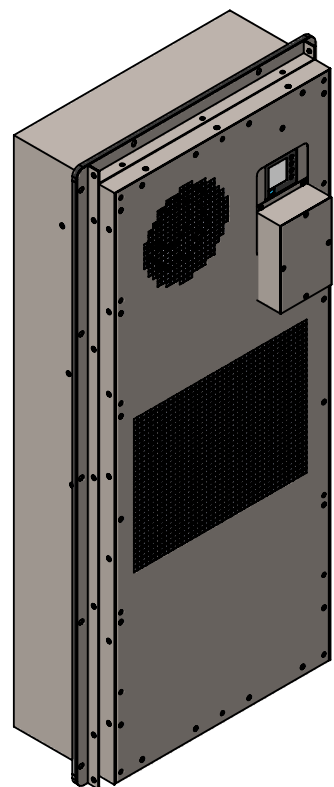

MODEL: IQ1000BDC

COOLING CAPACITY: 10236 BTU (3000W)

HEATING CAPACITY: 2730 BTU (800W)

OPERATING CURRENT: 20A (960W) @ 48VDC @ 95°F (35°C)

OPERATING TEMPERATURE RANGE: -40°F TO 131°F (-40°C TO 55°C) WITH LA PACKAGE

DIMENSIONS W/O FLANGES: 45.43" H (1154MM) X 19.25" W (489MM) X 8.86" D (225MM)

DIMENSIONS W/ FLANGES: 47.24" H (1200MM) X 21.06" W (535MM) X 8.86" D (225MM)

MAXIMUM SOUND LEVEL @ 5FT FROM UNIT @ A HT. OF 3FT: 60 dBA

MAXIMUM SOUND LEVEL @ 2FT FROM UNIT @ A HT. OF 5FT: 62.8 dBA

WEIGHT: 132.3 LBS (60KG)

REFRIGERANT: R134a

B	NEW METALWORK, VERTICAL CUTOUT ADDED, CFM DATA ADDED	JWS	9/1/2021				
A	INITIAL DRAFT	NAT	9/22/2020				
REV	REVISION	CHG	DATE	APP	DATE	CN#	

ITEM NUMBER N/A	USED ON IQ1000BDC
MATERIAL N/A	
EST WT: lbs	
DRAWN BY NAT	DATE 9/22/2020
	SCALE 1:12

UNLESS OTHERWISE SPECIFIED TOLERANCES
.X ±.060
.XX ±.030
.XXX ±.015
FRACTIONAL ±1/16
ANGULAR ±1/2°
SURFACE FINISH 63
DO NOT SCALE DRAWING DIMENSIONS ARE INCHES

ICE QUBE, INC.
THIS IS A PROPRIETARY DOCUMENT. DO NOT REPRODUCE OR DISCLOSE WITHOUT THE EXPRESS WRITTEN PERMISSION OF ICE QUBE, INC.

DESCRIPTION
SPEC DRAWING

DRAWING NUMBER
IQ352501

REV
B

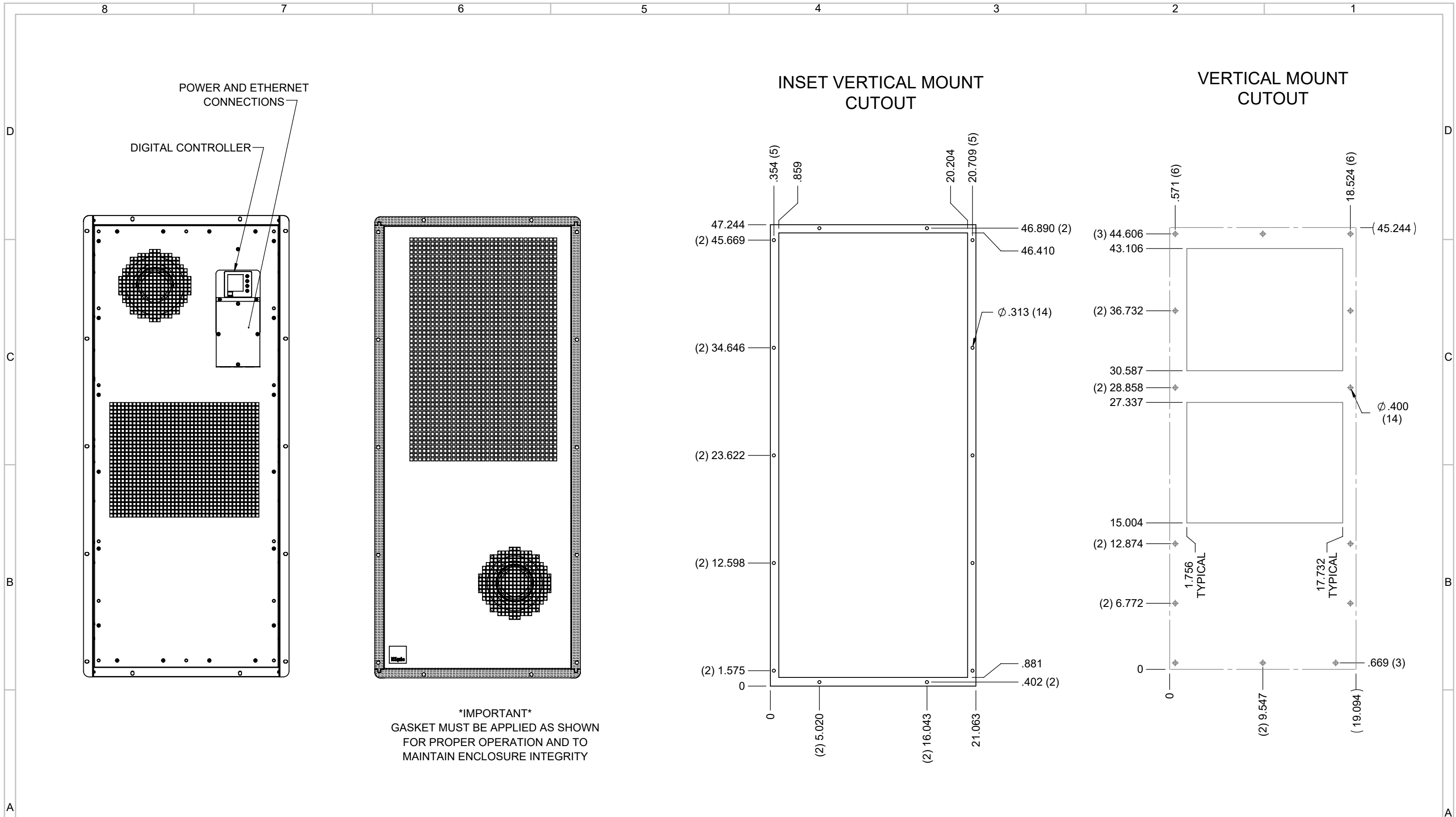

IMPORTANT
 GASKET MUST BE APPLIED AS SHOWN
 FOR PROPER OPERATION AND TO
 MAINTAIN ENCLOSURE INTEGRITY

EVAP. OUTLET ≈ 688 CFM
 COND. OUTLET ≈ 790 CFM

ITEM NUMBER N/A	USED ON IQ10000BDC	UNLESS OTHERWISE SPECIFIED TOLERANCES X ±.060 .XX ±.030 .XXX ±.015	ICE QUBE, INC. THIS IS A PROPRIETARY DOCUMENT. DO NOT REPRODUCE OR DISCLOSE WITHOUT THE EXPRESS WRITTEN PERMISSION OF ICE QUBE, INC.
MATERIAL N/A		FRACTIONAL ±1/4 ANGULAR ±1/2°	
EST WT: lbs	DATE 9/22/2020	SCALE 1:9	DESCRIPTION SPEC DRAWING
DRAWN BY NAT			DRAWING NUMBER IQ352501
			REV B